

INLET BOXES AND INLET-BOX DAMPERS

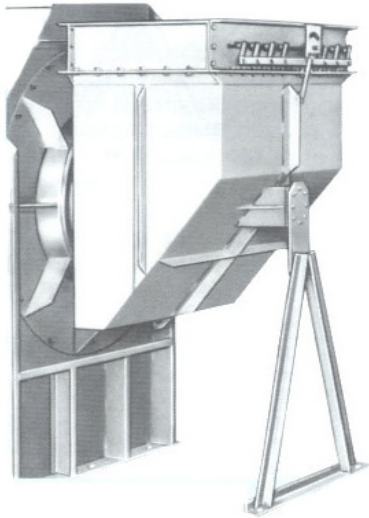

Available on these Arrangement 1, 4, 8, 9, 9F, and 10 fans:

GENERAL PURPOSE FANS
ACOUSTAFOIL/PLR FANS
CLASS IV FANS
AF FANS
RTS FANS
GI FANS
HPBC FANS
BC FANS
BCPB FANS

INLET BOXES

An inlet box is often used to accomplish a 90° turn into the fan inlet. The use of a properly designed inlet box will provide predictable minimum entry losses normally associated with a 90° turn at the fan inlet...see page 4 for correction factors.

The inlet box is designed to attach to the inlet flange of the fan. A support leg with mounting plate is standard on all inlet boxes...see dimension tables on page 2. When a fan with inlet box is furnished complete with a unitary base or isolation base, **the base must be extended to meet the support leg.** See the separate Unitary Bases and Isolation Bases price list. The inlet box/support leg assembly is not intended to support additional weight from ductwork or any other system components.

Inlet boxes can also be equipped with drains and bolted cleanout doors.

INLET-BOX DAMPERS

A parallel-blade inlet-box damper will control airflow by spinning the air into the fan. Reducing airflow by means of an inlet-box damper saves horsepower, similar to an outlet damper.

Parallel-blade inlet-box dampers are available with the following bearing options for the maximum temperature shown:

- Standard aluminum sleeve bushings 300°F.
- Optional stainless-steel bushings 1000°F.
- Optional stuffing-box construction 1000°F.
- Optional ball-bearing construction 800°F.

Notes:

1. Maximum safe operating temperature of the fan may be lower than inlet-box damper limits.
2. High-temperature paint is furnished for operation above 300°F.
3. Stainless-steel vanes and vane rods are furnished for operation above 800°F.

Inlet boxes and inlet-box dampers are normally shipped separate from the fan . . . refer to separate Installation and Maintenance Instructions for further information.

INLET-BOX POSITIONS

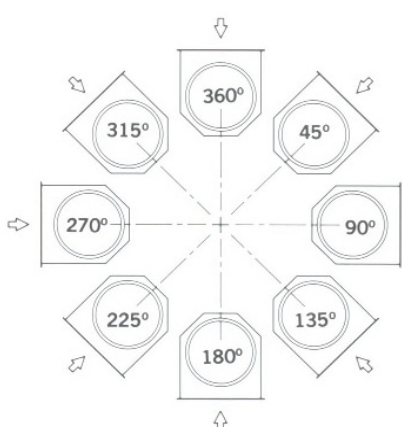

Position of inlet box is determined from drive side of fan. Inlet box positions 135°, 180°, and 225° often require special construction to avoid interference with the fan support structure. When other accessories such as an inlet-box damper or unitary base are required, a special layout is necessary...consult **nyb.**



THE NEW YORK BLOWER COMPANY
 7660 Quincy Street
 Willowbrook, IL 60527-5530

Visit us on the Web: <http://www.nyb.com>
 Phone: (800) 208-7918 Email: nyb@nyb.com

INLET BOXES FOR ACOUSTAFOIL/PLR FANS, AF FANS, BC FANS, BCPB FANS, CLASS IV FANS, HPBC FANS, GENERAL PURPOSE FANS, RTS

1. Refer to page 3 for rectangular flange dimensions.
2. Round flange dimensions on inlet box match fan inlet flange dimensions.
3. Base-bar dimensions match fan pedestal base-bar dimension T.
4. Dimensions are in inches.
5. Dimensions not to be used for construction unless certified.

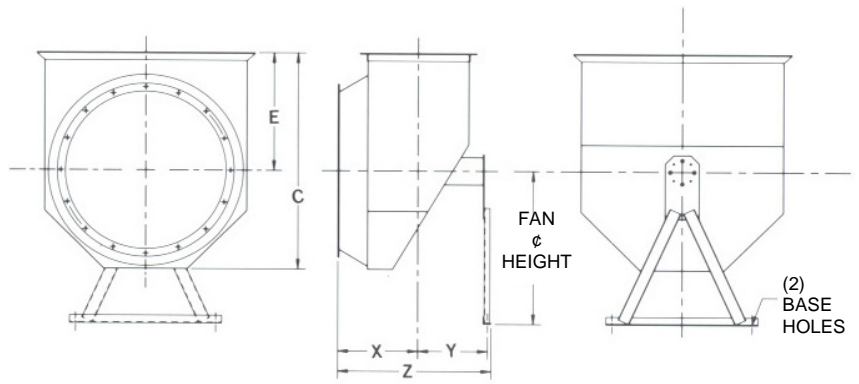

DIMENSIONS [inches]

Fan size			Fan inlet area [ft.]	C	E	X	Y	Z	Base hole diameter				Gauge	Weight [lbs.]
GP BC AcF/PLR Class IV	AF RTS HPBC	BCPB							GP BC AcF/PLR Class IV	AF, RTS, HPBC	BCPB	Class IV w/HDI Option		
15	--	24	1.460	229/16	123/8	87/16	815/16	18	9/16	--	3/4	9/16	12	83
16	--	27	1.760	243/4	131/2	91/4	911/16	199/16	9/16	--	3/4	9/16	12	83
18	--	30	2.181	271/2	15	101/8	103/4	211/2	9/16	--	3/4	9/16	12	83
20	24	33	2.578	307/16	169/16	111/8	111/8	227/8	9/16	3/4	3/4	9/16	12	98
22	27	36	3.341	331/2	181/4	121/4	115/8	241/2	9/16	3/4	1	3/4	12	113
24	30	40	3.939	37	201/8	139/16	123/16	263/8	3/4	3/4	1	3/4	12	140
27	33	44	4.746	401/2	22	147/8	127/8	283/8	3/4	3/4	1	3/4	12	168
30	36	49	5.894	451/8	241/2	169/16	1311/16	307/8	3/4	1	1	3/4	10	242
33	40	54	7.117	495/8	27	183/16	169/16	355/8	3/4	1	1	3/4	10	288
36	44	60	8.781	551/8	30	201/16	177/16	383/8	7/8	1	1	1	10	347
40	49	66	10.499	601/4	323/4	22	183/8	411/4	7/8	1	1	1	10	419
44	54	73	13.028	671/8	361/2	247/16	195/16	445/8	7/8	1	1	1	10	514
49	60	--	15.830	74	401/4	27	203/8	481/4	7/8	1	--	1	10	619
54	66	--	19.228	815/8	443/8	297/8	243/4	557/8	1	1	--	1	10	732
60	73	--	23.848	903/4	493/8	33	263/16	601/2	1	1	--	1	10	876
66	80	--	28.767	993/4	541/4	361/4	275/8	651/4	1	1	--	1	10	926
73	89	--	35.454	1103/4	601/4	401/8	291/4	703/4	1	1	--	1	10	1129
80	--	--	42.839	1221/2	665/8	423/4	311/8	751/4	1	--	--	--	10	1611
89	--	--	51.982	1353/8	735/8	455/8	33	80	1	--	--	--	10	1920

Tolerance: ±1/8"

INLET BOXES FOR GI FANS

1. Refer to page 3 for rectangular flange dimensions.
2. Round flange dimensions on inlet box match fan inlet flange dimensions.
3. Base-bar dimensions match fan pedestal base-bar dimension T.
4. Dimensions are in inches.
5. Dimensions not to be used for construction unless certified.

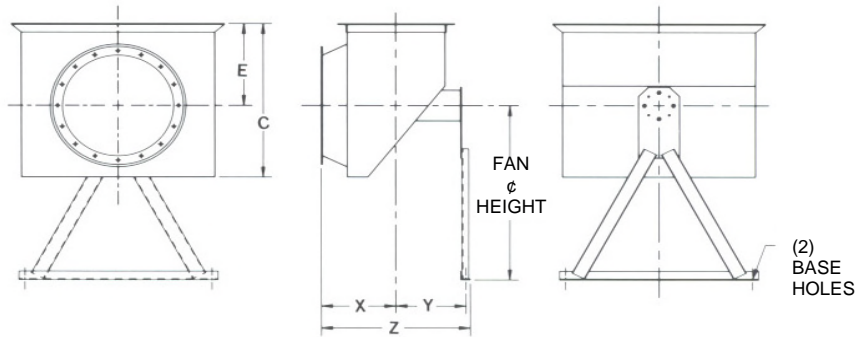

DIMENSIONS [inches]

Fan Size	Fan Inlet Area [ft. ²]	C	E	X	Y	Z	Base hole diameter	Gauge	Wt. [lbs.]
224	.921	19 3/4	10 1/2	8 7/8	8	17 1/2	9/16	12	64
264	1.227	22 3/4	12 1/8	10 1/8	9	19 3/4	3/4	12	81
294	1.576	25 7/8	13 3/4	11 1/2	9 5/8	21 3/4	3/4	12	102
334	1.968	29	15 1/2	12 3/4	10 3/8	23 3/4	3/4	12	126
364	2.405	32 1/8	17 1/8	14 1/8	13 1/8	28 1/8	7/8	12	159
404	2.885	35 1/8	18 3/4	15 1/2	13 7/8	30 1/4	7/8	12	203
454	3.687	39 7/8	21 1/4	18 1/2	14 1/2	33 7/8	7/8	12	255
504	4.586	44 1/2	23 3/4	19 9/16	15 9/16	36	1	12	310
574	5.939	50 5/8	27 1/8	21 3/4	16 7/8	40	1	10	435
644	7.466	56 5/8	30 1/4	24 11/16	18 1/16	44 1/8	1	10	522
714	9.168	62 7/8	33 5/8	27 7/16	19 5/16	48 1/8	1	10	620
784	11.044	69	36 7/8	30 1/16	20 7/16	51 7/8	1	10	722
854	13.095	75 1/4	40 1/4	32 3/4	21 1/2	55 5/8	1	10	836

**INLET BOX DAMPERS FOR
ACOUSTAFoil/PLR FANS, AF
FANS, BC FANS, BCPB FANS,
CLASS IV FANS, GENERAL
PURPOSE FANS,
GI FANS, HPBC FANS, RTS FANS**

1. A and B are inside dimensions.
2. Control arm (1/4" x 1-1/4" bar), for manual or automatic operation, supplied on side away from fan.
3. Control arm swings 45° each side of centerline.
4. Damper flange is 7-gauge steel with holes on 4" centers from centerlines.
5. Stuffing-box damper furnished with packing boxes on vane rods on linkage side, and with caps on the side opposite the linkage.
6. Specify fan rotation.
7. Dimensions are in inches.
8. Dimensions not to be used for construction unless certified.

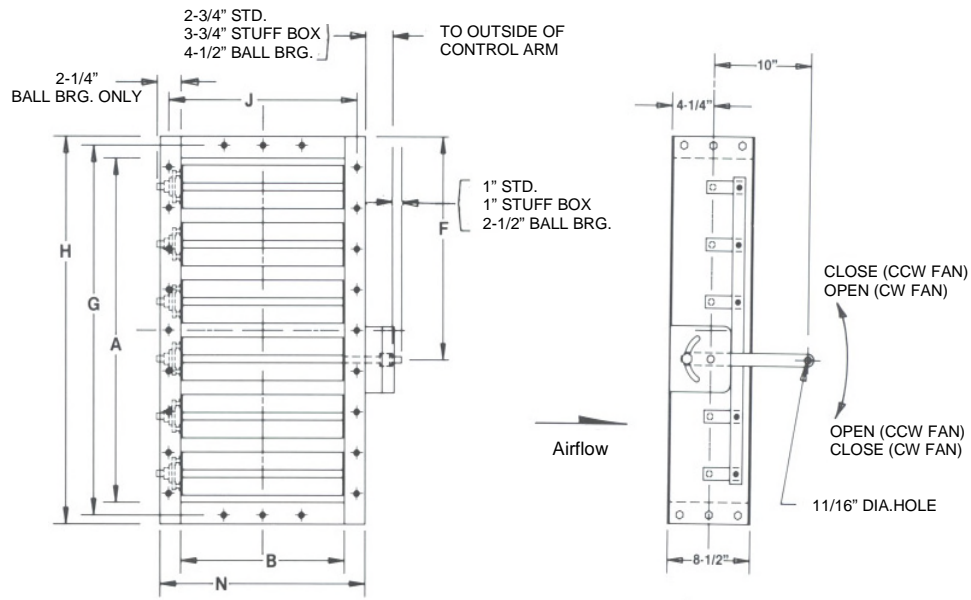

**DIMENSIONS[inches]
GENERAL PURPOSE FANS, ACOUSTAFoil/PLR FANS,
CLASS IV FANS, AF FANS, RTS FANS, HPBC FANS**

Fan Size			Damper Inlet Area [ft ²]	A	B	F	G	H	J	N	Flange Holes			Wt. [lbs.]
GP, AcF/PLR Cl. IV	AF, RTS HPBC	BCPB									Number			
											Sides	Top & Bottom	Dia.	
15	--	24	1.46	20 1/2	10 1/4	9 3/8	22 1/2	23 3/4	12 1/4	13 1/2	10	6	7/16	62
16	--	27	1.76	22 1/2	11 1/4	12 7/8	24 1/2	25 3/4	13 1/4	14 1/2	10	6	7/16	54
18	--	30	2.17	25	12 1/2	14 1/8	27	28 1/4	14 1/2	15 3/4	14	6	9/16	71
20	24	33	2.67	27 3/4	13 7/8	10	29 3/4	31	15 7/8	17 1/8	14	6	9/16	81
22	27	36	3.23	30 1/2	15 1/4	16 7/8	32 1/2	33 3/4	17 1/4	18 1/2	18	6	9/16	91
24	30	40	3.96	33 3/4	16 7/8	21 7/8	36 1/4	38	19 3/8	21 1/8	18	10*6†	9/16	103
27	33	44	4.75	37	18 1/2	20 5/8	39 1/2	41 1/4	21	22 3/4	18	10	9/16	117
30	36	49	5.91	41 1/4	20 5/8	22 3/4	43 3/4	45 1/2	23 1/8	24 7/8	22	10	9/16	133
33	40	54	7.11	45 1/4	22 5/8	27 5/8	47 3/4	49 1/2	25 1/8	26 7/8	26	10	9/16	152
36	44	60	8.77	50 1/4	25 1/8	27 1/4	52 3/4	54 1/2	27 5/8	29 3/8	26	14*/10†	9/16	173
40	49	66	10.50	55	27 1/2	32 3/8	57 1/2	59 1/4	30	31 3/4	30	14	9/16	197
44	54	73	13.03	61 1/4	30 5/8	35 7/8	63 3/4	65 1/2	33 1/8	34 7/8	34	14	9/16	228
49	60	--	15.82	67 1/2	33 3/4	35 7/8	70	71 3/4	36 1/4	38	34	18	9/16	264
54	66	--	19.27	74 1/2	37 1/4	39 3/8	77	78 3/4	39 3/4	41 1/2	38	18	9/16	300
60	73	--	23.78	82 3/4	41 3/8	47	85 1/4	87	43 7/8	45 5/8	42	22	9/16	345
66	80	--	28.75	91	45 1/2	50 3/4	93 1/2	95 1/4	48	49 3/4	46	26	9/16	403
73	89	--	35.42	101	50 1/2	52 5/8	103 1/2	105 1/4	53	54 3/4	50	26	9/16	465
80	--	--	43.26	111 3/4	55 3/4	58	114 1/4	116	58 1/4	60	58	26	9/16	556
89	--	--	52.74	123 1/2	61 1/2	63 7/8	126	127 3/4	64	65 3/4	62	30	9/16	648

*Inlet † Inlet-box damper

Tolerance: ± 1/8"

DIMENSIONS [inches] - GI FANS

Fan Size	Damper Inlet Area [ft ²]	A	B	F	G	H	J	N	Flange Holes			Wt. [lbs.]
									Number			
									Side	Top & bottom	Dia.	
224	1.76	22 1/2	11 1/4	12 7/8	24 1/2	25 3/4	13 1/4	14 1/2	14	6	7/16	62
264	2.35	26	13	14 5/8	28	29 1/4	15	16 1/4	14	6	7/16	73
294	3.02	29 1/2	14 3/4	16 3/8	31 1/2	32 3/4	16 3/4	18	14	6	7/16	85
334	3.78	33	16 1/2	20 7/8	35	36 1/4	18 1/2	19 3/4	18	10*6†	7/16	98
364	4.63	36 1/2	18 1/4	19 7/8	38 1/2	39 3/4	20 1/4	21 1/2	18	10	7/16	110
404	5.56	40	20	22 1/8	42 1/2	44 1/4	22 1/2	24 1/4	22	10	9/16	122
454	7.19	45 1/2	22 3/4	24 7/8	48	49 3/4	25 1/4	27	26	10	9/16	145
504	8.94	50 3/4	25 3/8	27 1/2	53 1/4	55	27 7/8	29 5/8	26	14	9/16	170
574	11.58	57 3/4	28 7/8	33 7/8	60 1/4	62	31 3/8	33 1/8	30	14	9/16	201
644	14.56	64 3/4	32 3/8	34 1/2	67 1/4	69	34 7/8	36 5/8	34	14	9/16	236
714	17.88	71 3/4	35 7/8	38	74 1/4	76	38 3/8	40 1/8	38	18	9/16	268
784	21.53	78 3/4	39 3/8	44 3/8	81 1/4	83	41 7/8	43 5/8	42	18	9/16	308
854	25.68	86	43	48 1/4	88 1/2	90 1/4	45 1/2	47 1/4	46	22	9/16	352

*Inlet box † Inlet-box damper

Tolerance: ± 1/8"

CORRECTION FACTORS FOR DETERMINING PERFORMANCE OF FANS WITH INLET BOXES

When a fan is equipped with an inlet-box, the fan must be selected at a pressure that compensates for losses occurring as a result of the inlet-box configuration. The required steps for selection and an example are shown below. See the next page to determine the pressure drop through the inlet-box damper and damper operating torque for actuator selection.

STEPS

1. Determine air velocity at fan inlet
 $CFM \div \text{fan inlet area} = V$ [air velocity].
2. Determine velocity pressure at fan inlet.
 $VP = [V \div 4005]^2 \times [\text{density} \div .075]$
3. Determine VP/SP ratio at conditions.
4. Determine VP factor from appropriate chart at right.
5. Determine inlet-box loss by multiplying the VP factor times the velocity pressure from Step 2.
6. Add the loss from Step 5 to the required system SP at conditions and select fan accordingly.

EXAMPLE

Required: A Size 504 Series 20 GI Fan, DH wheel, for 23,100 CFM at 12" SP at 70°F. at sea level.

1. 23,100 CFM $\div 4.586$ [fan inlet area, see page 2] = 5037 FPM.
2. $[5037 \div 4005]^2 = 1.58$ " VP
3. 1.58 " VP $\div 12$ " SP = 0.132 VP/SP.
4. VP factor at 0.132 VP/SP = 0.115 [from Chart III].
5. 0.115×1.58 " VP = 0.18 " loss.
6. 0.18 " + 12 " = 12.18 " SP. Select fan, motor, and drive for 23,100 CFM at 12.18 " SP at 70°F. at sea level.

NOTE: The above procedure does not consider the slight change in efficiency. Actual operation will result in slightly lower horsepower. Consult the fan selection program for performance curves illustrating precise fan capacity and horsepower data.

CHART 1
ACOUSTAFOIL/PLR FANS, CLASS IV FANS GENERAL, PURPOSE FANS

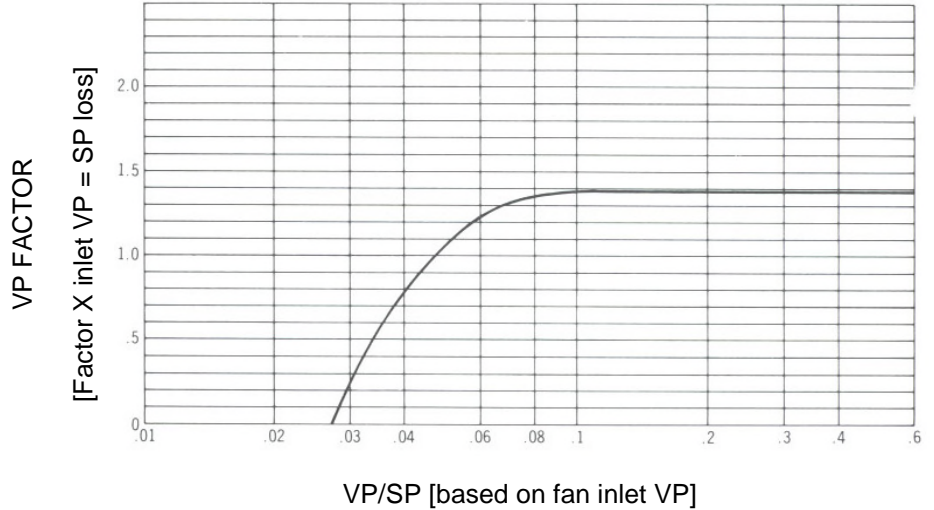

CHART II
AF FANS, BC FANS, BCPB FANS, HPBC FANS, RTS FANS

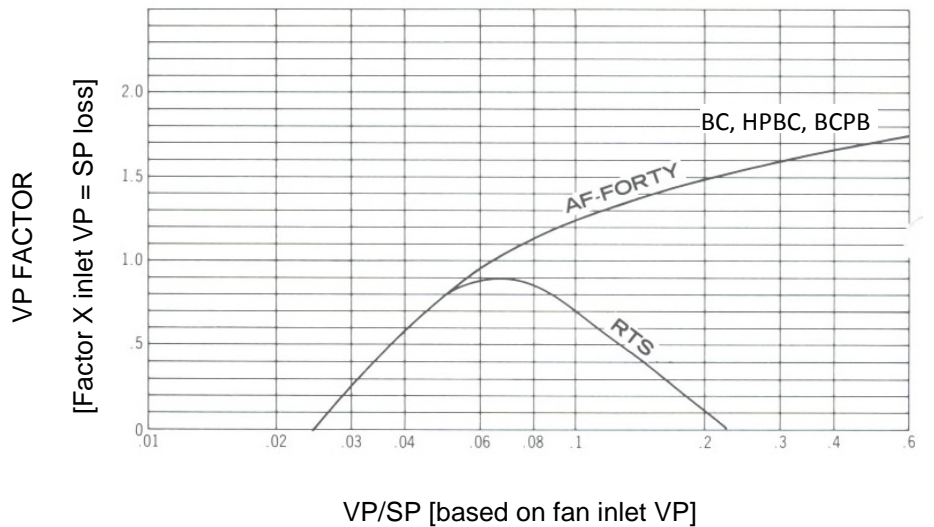
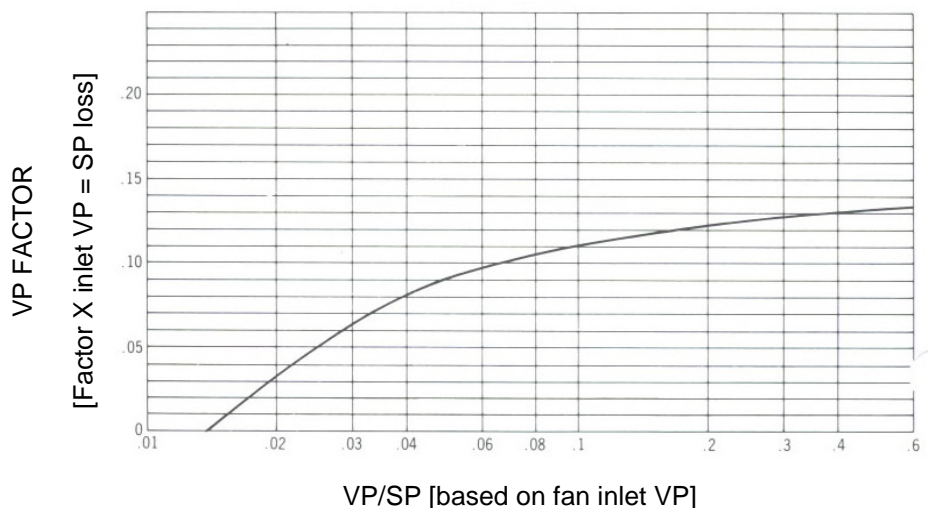

CHART III
GI FANS



CORRECTION FACTORS FOR DETERMINING PERFORMANCE OF FANS WITH INLET BOX DAMPERS

DAMPER STATIC PRESSURE DROP

Dampers, even in a wide-open position, create system resistance. Consequently, static pressure loss across a damper should be added to the total system resistance when sizing a fan in a critical operation. The following procedure can be used to estimate the static pressure drop across a fully open **nyb** inlet box damper. Note: Where system designers have considered damper pressure drop in their calculation of total system resistance, the damper pressure drop need not be added again when selecting the fan.

STEPS TO FOLLOW		EXAMPLE: Determine the SP drop across a fully open damper mounted on a Size 454 Series 30 GI Fan handling 18,450 CFM of standard density air, .075 lbs./cu. ft.
1	Determine the Air Velocity, V[FPM], at the damper. Velocity = CFM/Area where CFM is the Air Volume in cubic feet per minute and Area is the inside area of the damper (page 3).	$V = 18,450/7.19 \text{ ft.}^2 = 2566 \text{ FPM}$
2	Determine Velocity Pressure, VP, at the damper. $VP = \left[\frac{\text{Velocity}}{4005} \right]^2 \times \frac{\text{gas density}}{.075}$	$VP = \left[\frac{2566}{4005} \right]^2 \times \frac{.075}{.075} = 0.41" \text{ WG}$
3	Determine SP drop through the damper. SP drop = 0.24 x VP where 0.24 is an empirical constant and VP is Velocity Pressure from Step 2.	$SP \text{ drop} = 0.24 \times 0.41 = 0.10" \text{ WG}$

INLET BOX DAMPER OPERATING DATA

DAMPER OPERATING TORQUE

Determination of damper operating torque is a critical factor in the selection of an actuator. The operating torque of a damper is equal to the linkage torque at no-load conditions [no air flow or pressure] plus or minus the torque due to air resistance. Air resistance adds to the amount of force required to open a damper, but aids in closing a damper. Air resistance is a function of the damper type, area, and the peak fan static pressure at operating speed. Steps for determining damper operating torque are as follows:

STEPS TO FOLLOW		EXAMPLE: Determine the operating torque for an opposed blade damper on a Size 454 Series 30 GI Fan with a DH wheel operating at 1200 RPM.
1	Determine damper linkage torque, TL (<u>lb.in.</u>). $TL = 2 \times A$ where A is the inside height of the damper (page 3) and 2 is an empirical constant.	$T_L = 2 \times 45.5 = 91 \text{ lb. in.}$
2	Determine Air Resistance Torque. TA (<u>lb.in.</u>). $TA = 2.8 \times A \times SP$ where 2.8 is an empirical constant, A is the inside area (ft. ²) of the damper (page 3), and SP is the peak SP at the fan's operating RPM.	$T_A = 2.8 \times 7.19 \text{ ft.}^2 \times 16.8" \text{ WG}$ (obtained from fan performance curve) $= 338.2 \text{ lb.in}$
3	Determine operating torque, T, to open or close the damper. $T (\text{open}) = T_L + T_A$, or $T (\text{close}) = T_L - T_A$	$T (\text{open}) = 91 + 338.2 = 429 \text{ lb.in}$ $T (\text{close}) = 91 - 338.2 = 247.2 \text{ lb. in.}$

NOTE: The maximum static pressure capability of the fan can be used to calculate operating torque in the event that system requirements are subject to change.