



THE NEW YORK BLOWER COMPANY
7660 Quincy Street
Willowbrook, IL 60527-5530

Visit us on the Web: <http://www.nyb.com>
Phone: (800) 208-7918 Email: nyb@nyb.com

INSTALLATION MAINTENANCE, OPERATING INSTRUCTIONS

IM-190

PLUG FANS PLENUM FANS



WORD ABOUT SAFETY

Beginning in June 2012, the above **WARNING** signage has been placed on all **nyb** fans, as specified by ISO and recommended by the European Union. Air moving equipment involves electrical wiring, moving parts, sound, and air velocity or pressure which can create safety hazards if the equipment is not properly installed, operated and maintained. To minimize this danger, follow these instructions as well as the additional instructions and warnings on the equipment itself.

All installers, operators and maintenance personnel should study AMCA Publication 410, "Recommended Safety Practices for Air Moving Devices", which is included as part of every shipment. Additional copies can be obtained by writing to New York Blower Company, 7660 Quincy St., Willowbrook, IL 60527.

ELECTRICAL DISCONNECTS

Every motor driven fan should have an independent disconnect switch to isolate the unit from the electrical supply. It should be near the fan and must be capable of being locked by maintenance personnel while servicing the unit, in accordance with OSHA procedures.

MOVING PARTS

All moving parts must have guards to protect personnel. Safety requirements vary, so the number and type of guards needed to meet company, local and OSHA standards must be determined and specified by the user. Never start a fan without having all safety guards installed. Check regularly for damaged or missing guards and do not operate any fan with guards removed. Fans can also become dangerous because of potential "windmilling", even though all electrical power is disconnected. Always block the rotating assembly before working on any moving parts.

SOUND

Some fans can generate sound that could be hazardous to exposed personnel. It is the responsibility of the system designer and user to determine sound levels of the system, the degree of personnel exposure, and to comply with applicable safety requirements to protect personnel from excessive noise. Consult **nyb** for fan sound power level ratings.

AIR PRESSURE AND SUCTION

In addition to the normal dangers of rotating machinery, fans present another hazard from the suction created at the fan inlet. This suction can draw materials into the fan where they become high velocity projectiles at the outlet. It can also be extremely dangerous to persons in close proximity to the inlet, as the forces involved can overcome the strength of most individuals. Inlets and outlets that are not ducted should be screened to prevent entry and discharge of solid objects.



Danger: Do Not Enter/Confined Space

ACCESS DOORS

The above **DANGER** decal is placed on all **nyb** cleanout doors. These doors, as well as access doors to the duct system, should never be opened while the fan is in operation. Serious injury could result from the effects of air pressure or suction. Quick-opening doors must have the door handle bolts securely tightened to prevent accidental or unauthorized opening. Bolted doors must be tightened for the same reason.

RECEIVING AND INSPECTION

The fan and accessories should be inspected on receipt for any shipping damage. Turn the wheel by hand to see that it rotates freely and does not bind. If dampers or shutters are provided, check these accessories for free operation of all moving parts. F.O.B. factory shipping terms require that the receiver be responsible for inspecting the equipment upon arrival. Note damage or shortages on the Bill of Lading and file any claims for damage or loss in transit. **nyb** will assist the customer as much as possible; however, claims must be originated at the point of delivery.

HANDLING AND STORAGE

Fans should be lifted by the base, mounting supports, or lifting eyes only. Never lift a fan by the wheel, shaft, motor, motor bracket, or any fan part not designed for lifting. A spreader should be used to avoid damage.

Whenever possible, fans and accessories should be stored in a clean, dry location to prevent rust and corrosion of steel components. If outdoor storage is necessary, protection should be provided. Cover the entire fan to prevent the accumulation of dirt and moisture in the housing. Cover motors with waterproof material. Refer to the bearing section for further storage instructions. Inspect the stored unit periodically. **Rotate the wheel by hand every two weeks to redistribute grease on internal bearing parts.**

FAN INSTALLATION

nyb wheels are dynamically balanced when fabricated. Fully assembled fans are test run at operating speeds to check the entire assembly for conformance to **nyb** vibration limits. Nevertheless, all units must be adequately supported for smooth operation. **Ductwork or stacks should be independently supported as excess weight may distort the fan housing and cause contact between moving parts.** Where vibration isolators are used, consult the **nyb** certified drawing for proper location and adjustment.

nyb fans are designed for smooth operation throughout the cataloged speed range. Vibration levels are dependent upon the rigidity of the support structure on which the fan is mounted. The optimum installation is one in which the Plug Fan mounting panel or Plenum Fan base is bolted directly to the main supporting structurals of the particular system (see Figure 1). By doing so, the entire machine provides the mass and rigidity necessary to insure smooth operation.

The Plug Fan mounting panel has a formed edge to add strength and the face of the panel is provided with prepunched holes. The Plenum Fan base is also provided with predrilled holes. These holes are large enough to allow alignment at the time of installation yet still accept a large enough mounting bolt or stud to ensure ample security. All of the mounting holes should be used.

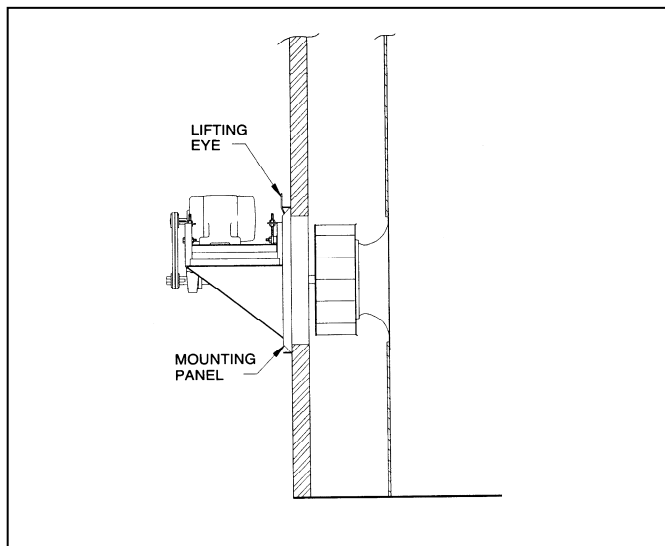

Figure 1
Typical Plug Fan Installation

For Plug Fans, the inlet cone support must be supplied by the user. In most cases, this is an internal baffle or plenum wall. The baffle or wall must be properly located and be straight to ensure optimum wheel-to-inlet cone clearance. It must also be sufficiently rigid to prevent movement of the cone during operation.

V-BELT DRIVE

Installation

1. Remove all foreign material from the fan and motor shafts. Coat shafts with machine oil for easier mounting. Mount all guards at this time if partial installation is required prior to sheave mounting.
2. Mount sheaves on shafts after checking sheave bores and bushings for nicks or burrs. Avoid using force. If resistance is encountered, lightly polish the shaft with emery cloth until the sheave slides on freely. Tighten tapered bushing bolts sequentially so that equal torque is applied to each.
3. Adjust the motor on its base to a position closest to the fan shaft. Install belts by working each one over the sheave grooves until all are in position. Never pry the belts into place. On **nyb** packaged fans, sufficient motor adjustment is provided for easy installation of the proper size belts.
4. Adjust sheaves and the motor shaft angle so that the sheave faces are in the same plane. Check this by placing a straightedge across the faces of the sheaves. Any gap between the edge and sheave faces indicates misalignment. Important: This method is only valid when the width of the surface between the belt edge and the sheave face is the same for both sheaves. When they are not equal, or when using adjustable-pitch sheaves, adjust so that all belts have approximately equal tension. Both shafts should be at right angles to the center belt.

Belt Tensioning

1. Check belt tension with a tensioning gage and adjust using the motor slide base. Excess tension shortens bearing life while insufficient tension shortens belt life, can reduce fan performance and may cause vibration. The lowest allow-able tension is that which prevents slippage under full load. Belts may slip during start-up, but slipping should stop as soon as the fan reaches full speed. For more precise tensioning methods, consult the drive manufacturer's literature.
2. Recheck setscrews, rotate the drive by hand and check for rubbing, then complete the installation of the belt guard.
3. Belts tend to stretch somewhat after installation. Recheck tension after several days of operation. Check sheave alignment as well as setscrew and/or bushing bolt tightness.

START-UP

Safe operation and maintenance includes the selection and use of appropriate safety accessories for the specific installation. This is the responsibility of the system designer and requires consideration of equipment location and accessibility as well as adjacent components. All safety accessories must be installed properly prior to start-up.

Safe operating speed is a function of system temperature and wheel design. Do not under any circumstances exceed the maximum safe fan speed published in the **nyb** bulletin, which is available from your **nyb** field sales representative.

Procedure

1. If the drive components are not supplied by **nyb**, verify with the manufacturer that the starting torque is adequate for the speed and inertia of the fan.
2. Inspect the installation prior to starting the fan. Check for any loose items or debris that could be drawn into the fan or dislodged by the fan discharge. Check the interior of the fan as well. Turn the wheel by hand to check for binding.

3. Check drive installation and belt tension.
4. Check the tightness of all setscrews, nuts and bolts. When furnished, tighten hub setscrews with the wheel oriented so that the setscrew is positioned underneath the shaft.
5. Install all remaining safety devices and guards. Verify that the supply voltage is correct and wire the motor. "Bump" the starter to check for proper wheel rotation.
6. Use extreme caution when testing the fan with plenum ducting disconnected. Apply power and check for unusual sounds or excessive vibration. If either exists, see the section on Common Fan Problems. To avoid motor overload, do not run the fan for more than a few seconds if plenum is not fully installed. Without plenum ductwork, normal operating speed may not be obtained without motor overload. Once plenum ductwork is complete, check for correct fan speed and complete installation. Plenum ductwork and guards must be fully installed for safety.
7. Setscrews should be rechecked after a few minutes, eight hours and two weeks of operation (see Tables 1 & 2 for correct tightening torques).

NOTE: Shut the fan down immediately if there is any sudden increase in fan vibration.

Table 1 - WHEEL SETSCREW TORQUES

Setscrew Size Diameter (in.)	Carbon Steel Setscrew Torque*	
	lb.-in.	lb.-ft.
1/4	75	6.2
5/16	144	12
3/8	252	21
7/16	396	33
1/2	600	50
5/8	1164	97
3/4	2016	168
7/8	3204	267
1	4800	400

* Stainless Steel setscrews are not hardened and should not be tightened to more than 1/2 the values shown.

Table 2 - BEARING SETSCREW TORQUE, lb.-in.

Setscrew Diameter	Manufacturer				
	Link-Belt	Sealmaster	SKF	McGill	Dodge
#10	40	--	35	35	--
1/4	90	65	50	85	--
5/16	185	125	165	165	160
3/8	325	230	290	290	275
7/16	460	350	350	--	--
1/2	680	500	620	--	600
5/8	1350	1100	1325	--	1200
3/4	2350	--	--	--	2000

FAN MAINTENANCE

nyb fans are manufactured to high standards with quality materials and components. Proper maintenance will ensure a long and trouble-free service life.

Do not attempt any maintenance on a fan unless the electrical supply has been completely disconnected and locked. In many cases, a fan can windmill despite removal of all electrical power. The rotating assembly should be blocked securely before attempting maintenance of any kind.

The key to good fan maintenance is regular and systematic inspection of all fan parts. Inspection frequency is determined by the severity of the application and local conditions. Strict adherence to an inspection schedule is essential.

Regular fan maintenance should include the following:

1. Check the fan wheel for any wear or corrosion, as either can cause catastrophic failures. Check also for the build-up of material which can cause unbalance resulting in vibration, bearing wear and serious safety hazards. Clean or replace the wheel as required.
2. Check the V-belt drive for proper alignment and tension (see section on V-belt drives). If belts are worn, replace them as a set, matched to within manufacturer's tolerances. Lubricate the coupling of direct-drive units and check for alignment (see section on couplings).
3. Lubricate the bearings, but do not over lubricate (see the bearing section for detailed specifications).
4. Ceramic-felt shaft seals require no maintenance, although worn seals should be replaced.
5. During any routine maintenance, all setscrews and bolts should be checked for tightness. See tables for torques.
6. When installing a new wheel or cone, the proper wheel-to-inlet cone clearance must be maintained (see Figure 2).

WARNING: Do not remove or loosen the fan hub from the fan wheel. Removing or loosening the fan hub from the fan wheel will cause imbalance and void the warranty.

WHEEL BALANCE

Airstreams containing particulate or chemicals can cause abrasion or corrosion of the fan parts. This wear is often uneven and can lead to significant wheel unbalance over time. When such wear is discovered, a decision must be made as to whether to rebalance or replace the wheel.

The soundness of all parts should be determined if the original thickness of components is reduced. Be sure there is no hidden structural damage. The airstream components should also be cleaned to remove any build-up of foreign material. Specialized equipment can be used to rebalance a cleaned wheel that is considered structurally sound.

Balance weights should be rigidly attached at a point that will not interfere with the housing nor disrupt airflow. Remember that centrifugal forces can be extremely high at the outer radius of a fan wheel. Welding is the preferred method of balance weight attachment. Be sure to ground the welder directly to the fan wheel. Otherwise, the welding current could pass through the fan bearings and damage them.

WHEEL-CONE CLEARANCES

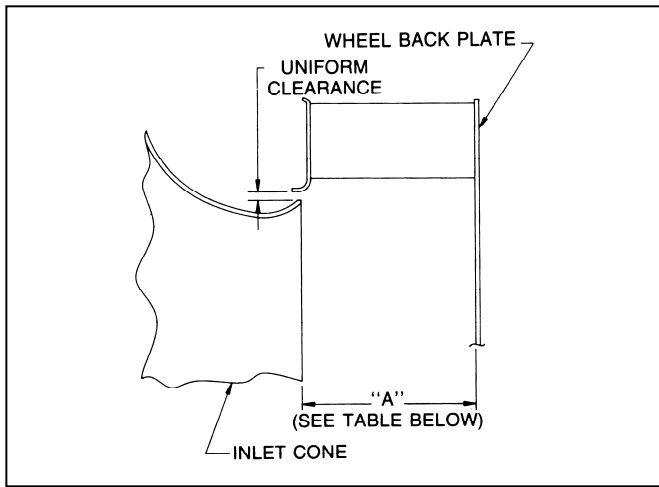

Fan Size	"A" Dimension		Fan Size	"A" Dimension	
	ECF	ACF, ACFq, BC, BCq, PLR		ECF-9, ECF-11	ACF, ACFq, BC, BCq, PLR
10	4	3 1/2	30	12	11 1/4
12	4 13/16	4 1/2	33	13 3/16	12 1/4
13	5 5/16	5	36	14 1/4	13 3/8
15	5 7/8	5 1/2	40	15 13/16	14 13/16
16	6 9/16	6 1/2	44	17 3/8	16 1/4
18	7 7/16	7	49	19 3/16	17 15/16
20	8 1/8	7 7/16	54	21 1/8	19 13/16
22	9	8 1/4	60	23 7/16	21 13/16
24	9 15/16	9 5/16	66	25 3/4	24
27	10 7/8	10 3/16	73	27 5/16	26 9/16

Figure 2

BEARINGS

Storage

Any stored bearing can be damaged by condensation caused by temperature variations. Therefore, **nyb** fan bearings are filled with grease at the factory to exclude air and moisture. Such protection is adequate for shipment and subsequent immediate installation.

For long term or outdoor storage, mounted bearings should be regreased and wrapped with plastic for protection. **Rotate the fan wheel by hand at least every two weeks to redistribute grease on internal bearing parts.** Each month the bearings should be purged with new grease to remove condensation, since even a filled bearing can accumulate moisture. Use caution when purging, as excessive pressure can damage the seals. Rotate the shaft while slowly adding grease.

Operation

Check the setscrew torque before start-up (see Table 2 for correct values). Since bearings are completely filled with grease at the factory, they may run at an elevated temperature during initial operation. Surface temperatures may reach 180°F. and grease may bleed from the bearing seals. This is normal and no attempt should be made to replace lost grease. Bearing surface temperatures will decrease when the internal grease quantity reaches a normal operating level. Relubrication should follow the recommended schedule.

Lubrication

Use the table for relubrication scheduling according to operating speed and shaft diameter. Bearings should be lubricated with a premium quality lithium-based grease conforming to NLGI Grade 2. Examples are:

Mobil	-	Mobilgrease XHP
Texaco	-	Premium RB
Chevron	-	Amolith #2
Shell	-	Alvania #2

Do not use "high temperature" greases, as many are not formulated to be compatible with fan bearings. Add grease to the bearing while running the fan or rotating the shaft by hand. Be sure all guards are in place if lubrication is performed while the fan is operating. Add just enough grease to cause a slight purging at the seals. Do not over lubricate. **Disposal of material should be made in accordance to local government regulations.**

COMMON FAN PROBLEMS

Excessive Vibration

A common complaint regarding industrial fans is "excessive vibration". **nyb** is careful to ensure that each unit is precisely balanced prior to shipment; however, there are many other causes of vibration including:

1. Loose mounting bolts, setscrews, bearings or couplings.
2. Misalignment or excessive wear of couplings or bearings.
3. Misaligned or unbalanced motor.
4. Bent shaft due to mishandling or material impact.
5. Accumulation of foreign material on the wheel.
6. Excessive wear or erosion of the wheel.
7. Excessive system pressure or restriction of airflow due to closed dampers.
8. Inadequate structural support, mounting procedures or materials.
9. Externally transmitted vibration.

Inadequate Performance

1. Incorrect testing procedures or calculations.
2. Fan running too slowly.
3. Fan wheel rotating in wrong direction.
4. Wheel not properly centered relative to inlet cone.
5. Poor system design, closed dampers, air leaks, clogged filters, or coils.
6. Obstructions or sharp elbows near inlets.
7. Sharp deflection of airstream at fan outlet.

Excessive Noise

1. Fan operating near "stall" due to incorrect system design or installation.
2. Vibration originating elsewhere in the system.
3. System resonance or pulsation.
4. Improper location or orientation of fan intake and discharge.
5. Inadequate or faulty design of supporting structures.
6. Nearby sound reflecting surfaces.
7. Loose accessories or components.
8. Loose drive belts.
9. Worn bearings.

Premature Component Failure

1. Prolonged or major vibration.
2. Inadequate or improper maintenance.
3. Abrasive or corrosive elements in the airstream or surrounding environment.
4. Misalignment or physical damage to rotating components or bearings.
5. Bearing failure from incorrect or contaminated lubricant or grounding through the bearings while arc welding.
6. Excessive fan speed.
7. Extreme ambient or airstream temperatures.
8. Improper belt tension.
9. Improper tightening of wheel setscrews.

BEARING LUBRICATION INTERVAL (months)

Shaft	RPM									
	1-500	501-1000	1001-1500	1501-2000	2001-2500	2501-3000	3001-3500	3501-4000	4001-4500	4501-5000
5/8 thru 1	6	6	5-6	5-6	4-6	4-6	3-4	3-4	2	2
1 3/16 thru 1 7/16	6 6	6 4	5-6 4	4-6 2	4-6 2	3-5 1	2-4 1	2-4 1	1-2 1	1 1/2
1 11/16 thru 1 15/16	6 6	6 4	4-6 2	4-6 1	2-4 1	2-4 1	2 1/2	1-2 1/2	1-2	1
2 3/16	6 6	5-6 4	4-6 2	3-4 1	2-4 1	1-2 1/2	1-2	1-2		
2 7/16	6 4	4-6 2	4-6 1	3-4 1	2 1/2	1-2 1/2	1-2	1		
2 11/16 thru 2 15/16	5-6 4	4-6 2	2-4 1	2 1	1-2 1/2	1				
3 3/16	6	6	4	2	2					
3 7/16 thru 4 3/16	4-6 4	3-5 2	2-4 1	1-2 1/2	1					

NOTE:

1. These are general recommendations only; specific manufacturer's recommendations may vary slightly.
2. Assumes clean environment, -20°F. to 120°F.
 - a. Consult The New York Blower Company for operation below -20°F. ambient.
 - b. Ambient temperatures greater than 120°F. will shorten bearing life.
3. Assumes horizontal mounting configuration. For vertically mounted applications, lubricate twice as frequently.
- c. Under extremely dirty conditions, lubricate more frequently.

LIMITED PRODUCT WARRANTY

All products are warranted by **nyb** to be free from defects in materials and workmanship for a period of one (1) year after shipment from its plant, provided buyer demonstrates to satisfaction of **nyb** that the product was properly installed and maintained in accordance with **nyb's** instructions and recommendations and that it was used under normal operating conditions.

This warranty is limited to the replacing and/or repairing by **nyb** of any part or parts which have been returned to **nyb** with **nyb's** written authorization and which in **nyb's** opinion are defective. Parts not manufactured by **nyb** but installed by **nyb** in equipment sold to the buyer shall carry the original manufacturer's warranty only. All transportation charges and any and all sales and use taxes, duties, imports or excises for such part or parts shall be paid for by the buyer. **nyb** shall have the sole right to determine whether defective parts shall be repaired or replaced.

This warranty does not cover any customer labor charges for replacement of parts, adjustments or repairs, or any other work unless such charges shall be assumed or authorized in advance, in writing, by **nyb**.

This warranty does not cover any product which, in the judgement of **nyb**, has been subject to misuse or neglect, or which has been repaired or altered outside **nyb's** plant in any way which may have impaired its safety, operation or efficiency, or any product which has been subject to accident.

This warranty shall be null and void if any part not manufactured or supplied by **nyb** for use in any of its products shall have been substituted and used in place of a part manufactured or supplied by **nyb** for such use.

There are no warranties, other than those appearing on the acknowledgement form **INCLUDING NO WARRANTY OF MERCHANTABILITY OR FITNESS FOR A PARTICULAR PURPOSE**, given in connection with the sale of the goods sold hereunder. The buyer agrees that his sole and exclusive remedy, and the limit of **nyb's** liability for loss from any cause whatsoever, shall be the purchase price of the goods sold hereunder for which a claim is made.

SPECIFY ROTATION AS VIEWED FROM DRIVE SIDE

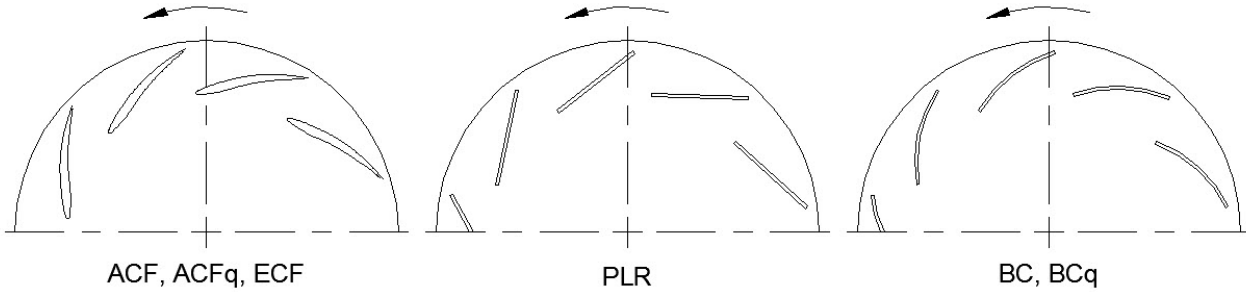

ARROW INDICATES COUNTER CLOCKWISE ROTATION

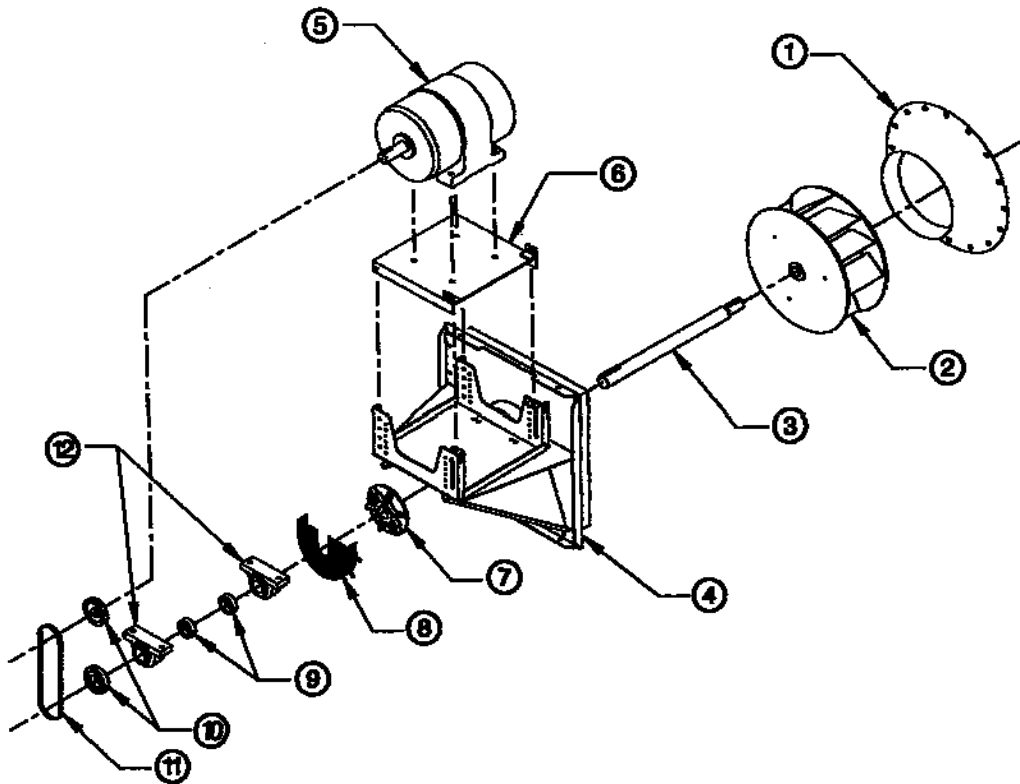

REPLACEMENT PARTS

It is recommended that only factory-supplied replacement parts be used. **nyb** fan parts are built to be fully compatible with the original fan, using specific alloys and tolerances. These parts carry a standard **nyb** warranty.

When ordering replacement parts, specify the part name, **nyb** shop control number, fan size, type, rotation (viewed from drive end), and bearing size or bore. Most of this information is on the metal nameplate attached to the fan base.

For assistance in selecting replacement parts, contact your local **nyb** representative or visit: <http://www.nyb.com>.

Example: Part required: Wheel
 Shop/control number: B-10106-100
 Fan Description: Size 27 Plug Fan
 Wheel: PLR
 Rotation: Clockwise

Parts List

- | | |
|----------------------------|-----------------------|
| 1. Inlet Cone | 7. Shaft Cooler |
| 2. Wheel | 8. Shaft Cooler Guard |
| 3. Shaft | 9. Shaft Set Collars |
| 4. Base and Mounting Panel | 10. Sheaves |
| 5. Motor | 11. V-Belts |
| 6. Motor Platform | 12. Bearings |

* Order for parts must specify rotation.

Suggested spare parts include:

- | | |
|--------------|------------------|
| Wheel | Component Parts: |
| Shaft | Motor |
| Bearings | Sheaves |
| Shaft Seal | V-Belts |
| Shaft Cooler | |

**ARRANGEMENT 3P
PLENUM FAN**

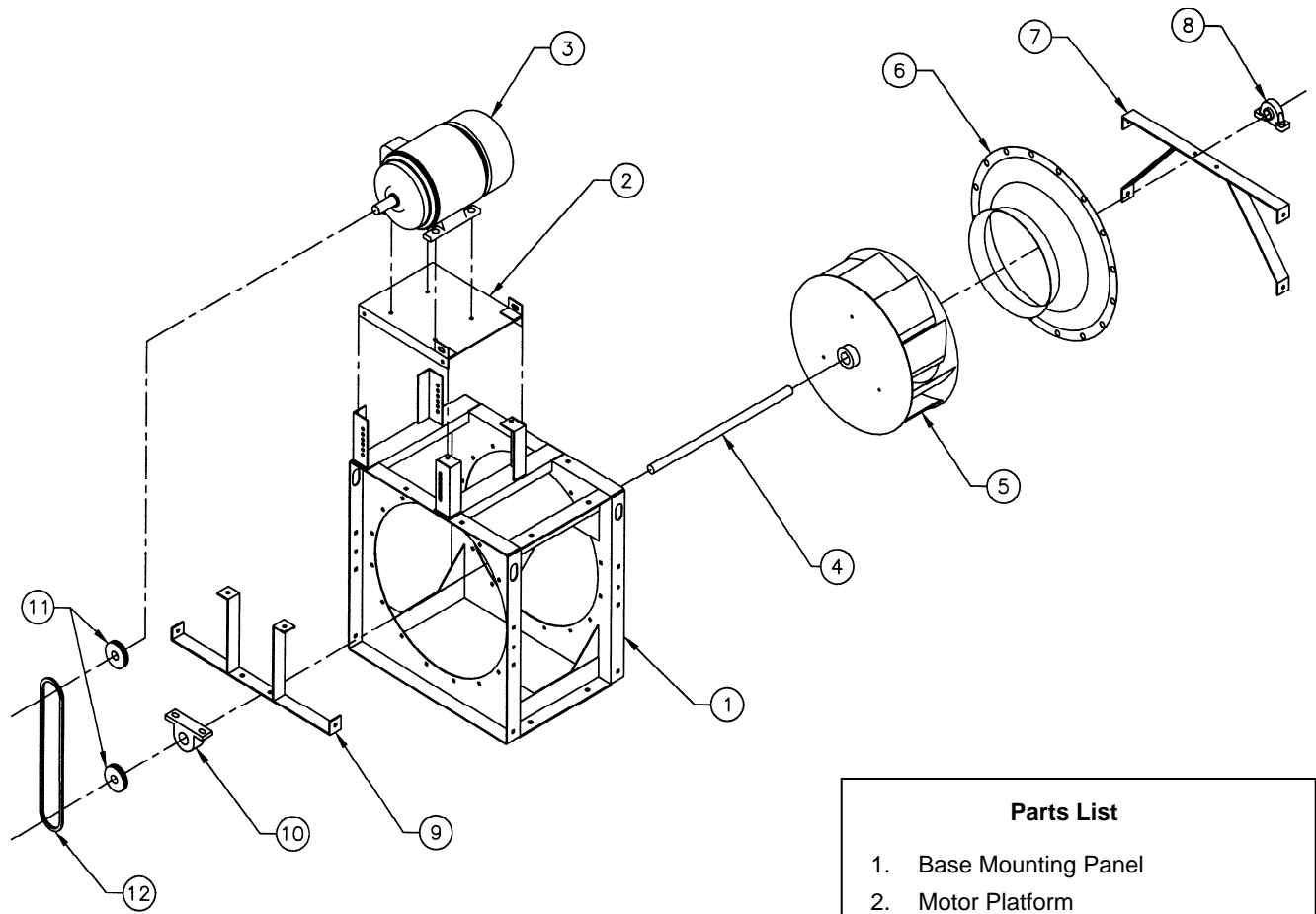

Parts List

1. Base Mounting Panel
2. Motor Platform
3. Motor
4. Shaft
5. Wheel
6. Inlet Cone
7. Inlet Side Bearing Support
8. Inlet Side Bearing
9. Drive Side Bearing Support
10. Drive Side Bearing
11. Drive Side Bearing Sheaves
12. V-Belts

For assistance in selecting replacement parts, contact your local **nyb** representative or visit: <http://www.nyb.com>

ARRANGEMENT 4 PLENUM FAN

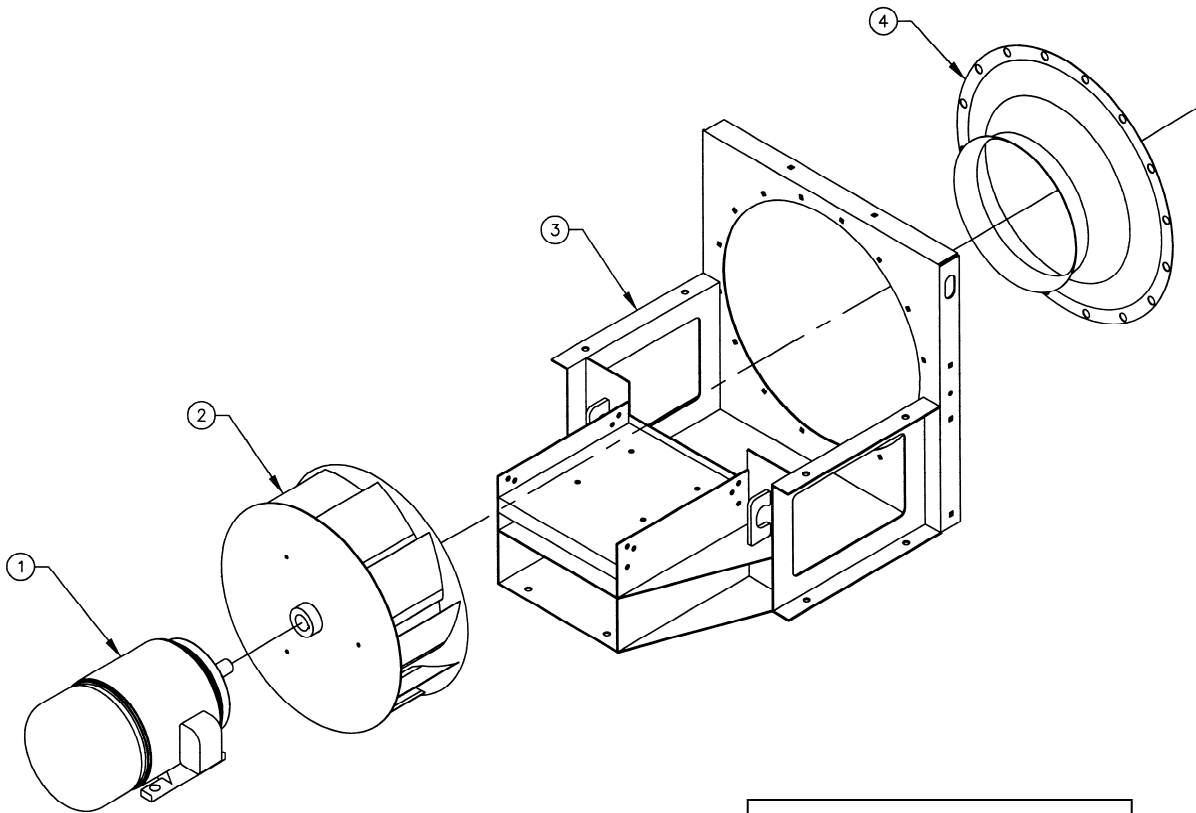

Parts List

1. Motor
2. Wheel
3. Base Mounting Panel
4. Inlet Cone

Suggested spare parts include:

Wheel	Component Parts:
Shaft	Motor
Bearings	Sheaves
Shaft Seal	V-Belts
Shaft Cooler	

For assistance in selecting replacement parts, contact your local **nyb** representative or visit: <http://www.nyb.com>.